

Produktový list

Objednací kód: **21611HA**

EVIA L HYDRO-AIR hydromasážní vana, 170x100x47cm, bílá

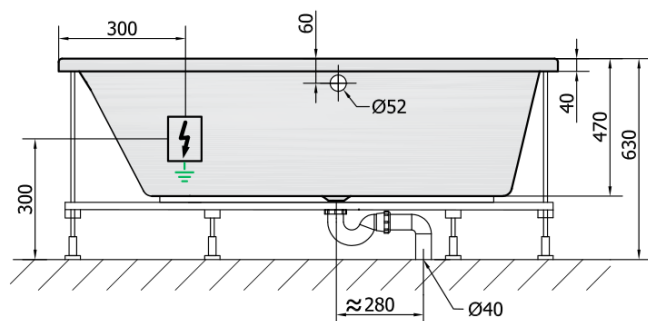

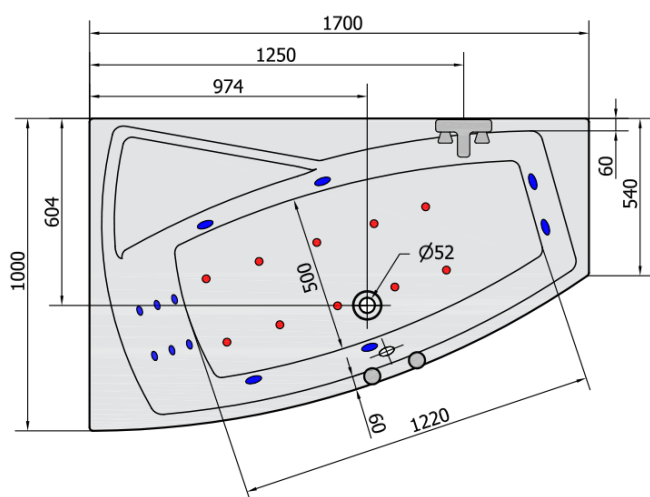

VOLUME 255L

H HYDRO
12 whirlpool jets
12 vodních trysek

A AIR
10 air jets
10 vzduchových trysek

Electric cable 3x2,5mm²
Length 2m from the wall

 Elektrický kabel 3x2,5mm²
 Délka kabelu ze zdi 2m

Electrical Characteristic:
Tension: 220-230V/50hz
Max. power consumption: 1200W
Electric protection: residual-current device 30mA

Elektrické vlastnosti:
Napětí: 220-230V/50hz
Max. spotřeba: 1200W
Elektrické jištění: proudový chránič 30mA